

DETAIL A
SCALE 1 : 5

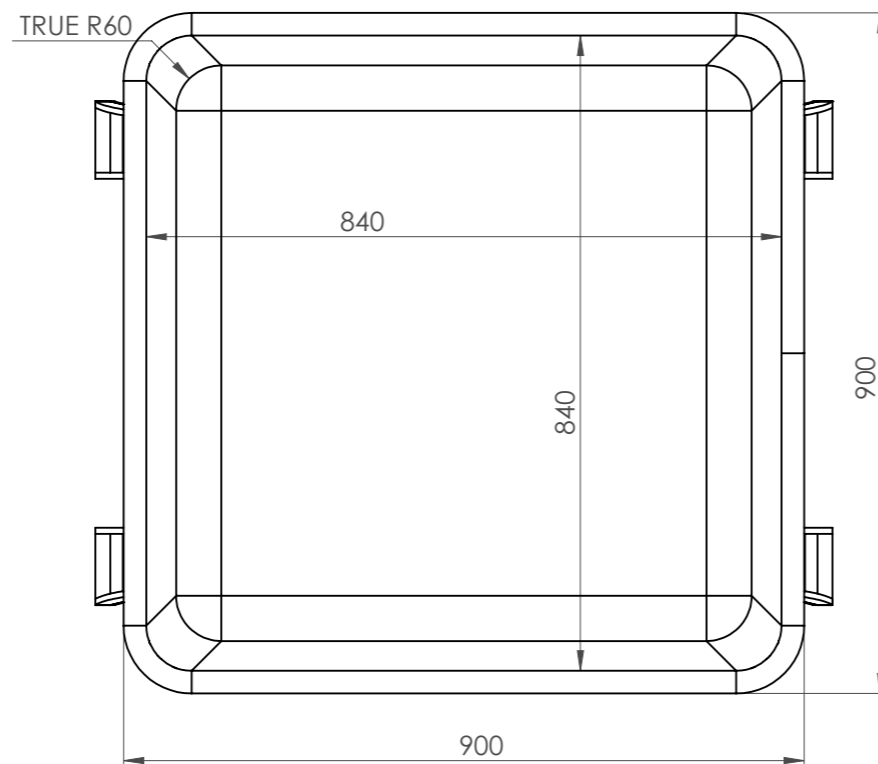
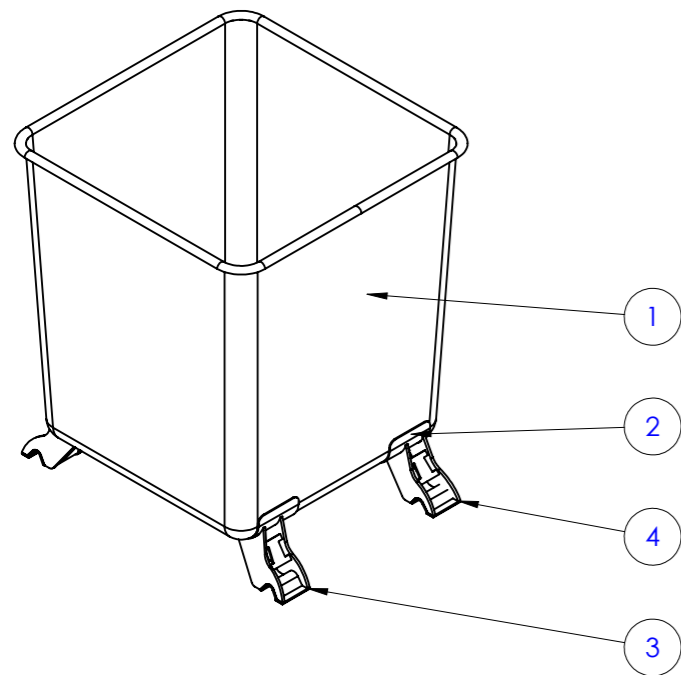
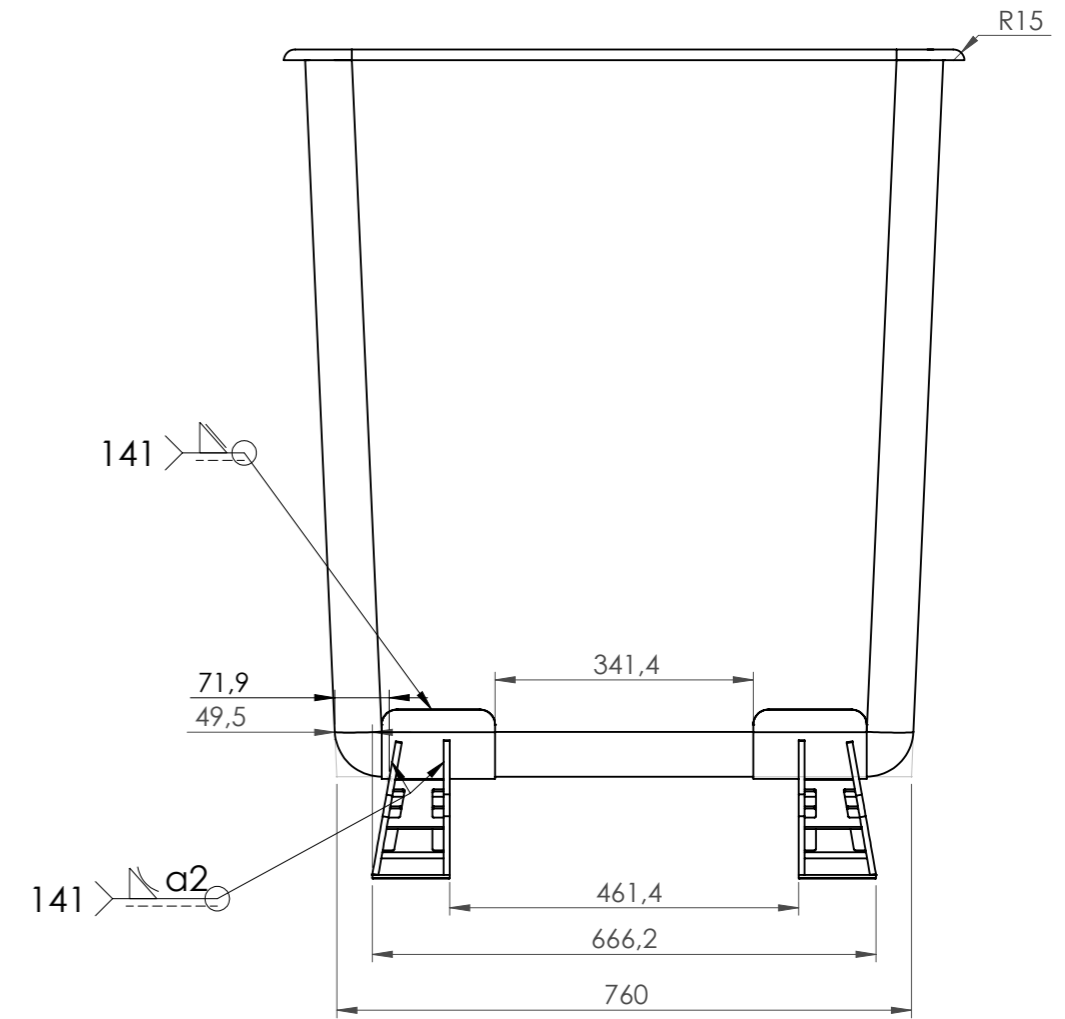
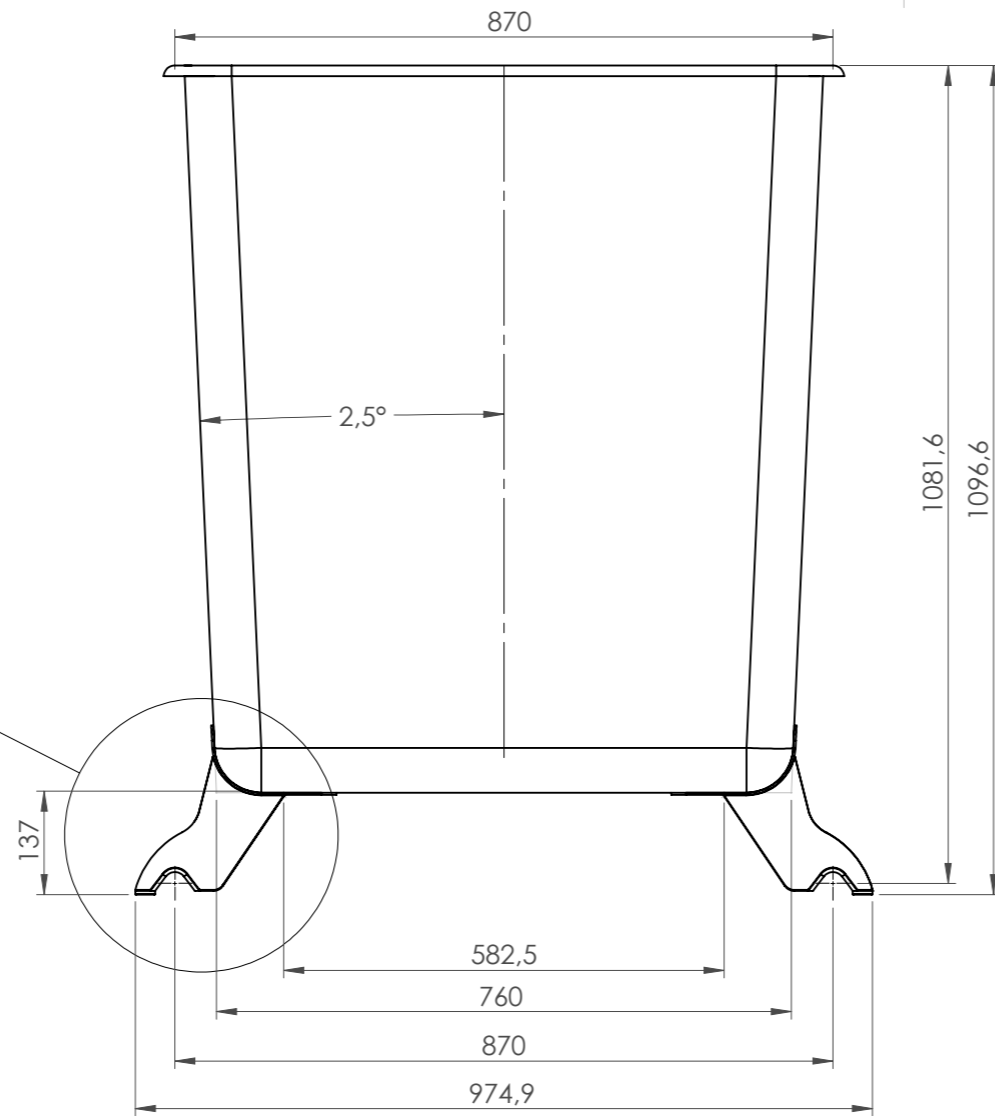

Pos.	Draw nr	Description	Group	QTY	Material
4	13-105	Leg assembly welded	03	2	
3	13-65	Leg assembly welded	03	2	
2	13-64	Support plate for leg	10	4	1.4301
1	13-57	Trolley container	01	1	1.4301

Treatment: Sharp edges removed.	Item Group: 03	Scale: 1:10	Format: A3
------------------------------------	-------------------	----------------	---------------

Creator: SHP	Date: 10-03-2020	Standard: DS/EN ISO 13920-AE
Drawing Creator: SHP	Date: 27-08-2020	Weight kg: 70.7

Trolley assembly	Drawing number: 13-56	Revision:
------------------	---------------------------------	-----------

This drawing, as well as any attachment(s), is the property of scansteel foodtech A/S and must not be copied or reproduced in whole or in part, by any method whatsoever, without written authorization from scansteel foodtech A/S.